



DP3111

PWM Control 3A Step-Down Converter

GENERAL DESCRIPTION

DP3111 consists of step-down switching regulator with PWM control. These device include a reference voltage source, oscillation circuit, error amplifier, internal PMOS and etc.

DP3111 provides low-ripple power, high efficiency, and excellent transient characteristics. The PWM control circuit is able to the duty ratio linearly from 0 up to 100%. This converter is built out soft start function that prevents overshoot and inrush current at startup. An over current protect function and short circuit protect function are built inside, and when OCP or SCP happens, the operation frequency will be reduced. The operating frequency is decided by outside resistance. An external compensation is easily to system stable.

With the addition of an internal P-channel Power MOS, a coil, capacitors, and a diode connected externally, these ICs can function as step-down switching regulators. They serve as ideal power supply units for portable devices when coupled with the SOP-8L with exposed pad package, providing such outstanding features as low current consumption. Since this converter can accommodate an input voltage up to 40V, it is also suitable for the operation via an AC adapter.

FEATURES

- Input voltage : 4.2V to 40V
- Output voltage : 0.8V to 38V
- Duty ratio : 0% to 100% PWM control
- Oscillation frequency range is 50K — 600KHz by outside resistance setting
- Current Limit, Short Circuit Protect (SCP) and Thermal Shutdown protection
- Built-in internal SW P-channel MOS.
- SOP-8L-EP Pb-Free package.

Block Diagram

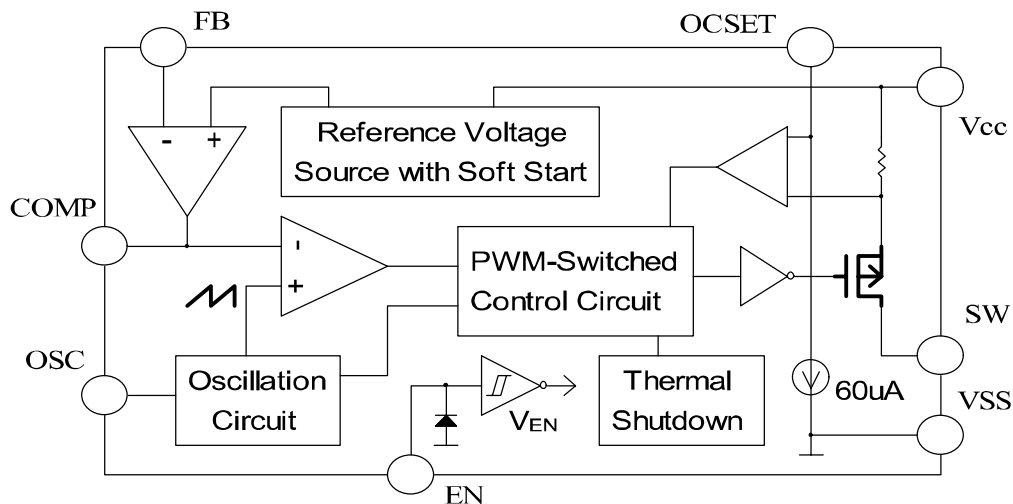



DP3111

PWM Control 3A Step-Down Converter

PIN ASSIGNMENT

The package of DP3111 is SOP8-EP; the pin assignment is given by:

<p style="text-align: center;">SOP8-EP</p>	Name	Description
	EN	ON/OFF Shutdown OPEN ON / L OFF
	VSS	GND pin
	OCSET	Add an external resistor to set max output current.
	VCC	IC power supply pin
	SW	Switch pin. Connect external inductor & diode here.
	FB	Feedback pin
	COMP	Compensation pin
	OSC	Frequency Set Pin. The pin connect a resistance to GND.

ORDER/MARKING INFORMATION

Order Information	Top Marking
<p>DP 3111 X</p> <p style="margin-left: 100px;">└─┬─┘</p> <div style="border: 1px solid black; padding: 5px; width: fit-content; margin-left: 100px;">Packing</div> <p>Blank: Tube A: Taping</p>	<p>DP 3111 → Part number</p> <p>XX XX → ID code: internal</p> <p style="margin-left: 40px;">└─┬─┘</p> <p style="margin-left: 60px;">→ WW: 01 -- 52</p> <p style="margin-left: 60px;">→ Year: 11= 2011</p>

Absolute Maximum Ratings (at Ta=25°C)

Characteristics	Symbol	Rating	Unit
VCC Pin Voltage	V_{CC}	$V_{SS} - 0.3$ to $V_{SS} + 42$	V
Feedback Pin Voltage	V_{FB}	$V_{SS} - 0.3$ to 6	V
EN Pin Voltage	$V_{EN/SS}$	$V_{SS} - 0.3$ to 6	V
OSC Pin Voltage	V_{OSC}	$V_{SS} - 0.3$ to 3	V
COMP Pin Voltage	V_{COMP}	$V_{SS} - 0.3$ to 6	V



DP3111

PWM Control 3A Step-Down Converter

OCSET Pin Voltage	V_{OCSET}	$V_{SS} - 0.3$ to V_{CC}	V
Switch Pin Voltage	V_{SW}	$V_{SS} - 0.3$ to $V_{CC} + 0.3$	V
Power Dissipation	PD	Internally limited	mW
Storage Temperature Range	T_{ST}	-65 to +150	°C
Operating Junction Temperature Range	T_{OJP}	-40 to +125	°C
Operating Supply Voltage	V_{OP}	4.2 to 40	V
Thermal Resistance from Junction to case	θ_{JC}	15	°C/W
Thermal Resistance from Junction to ambient	θ_{JA}	40	°C/W

Note: θ_{JA} is measured with the PCB copper area(need connect to Exposed Pad) of approximately 1.5 in²(Multi-layer).

Electrical Characteristics ($V_{CC} = 12V$, $T_a=25^\circ C$, unless otherwise specified)

Characteristics	Symbol	Conditions	Min	Typ	Max	Units
Feedback Voltage	V_{FB}	$V_{CC} = 10V \sim 30V$ $I_{OUT} = 0$ to $2A$ $T_j = -20^\circ C \sim 125^\circ C$	0.784	0.800	0.816	V
Quiescent Current	I_{CCQ}	$V_{FB} = 1.2V$ force driver off	-	3	6	mA
Feedback Bias Current	I_{FB}	$I_{OUT} = 0.1A$	-	0.1	0.5	µA
Shutdown Supply Current	I_{SD}	$V_{EN/SS} = 0V$	-	150	300	µA
Switch Current	I_{SW}		3.5	-	-	A
Adjustable frequency	F_{OSC}		50	-	600	KHz
Short frequency	F_{OSC} / F_{OSCS}	$V_{CC} = 10V \sim 30V$	5	6		
EN Pin Shutdown Logic input threshold voltage	V_{ENL}		-	-	0.8	V
Internal MOSFET R_{DSON}	R_{DSON}	$V_{CC} = 12V$, $V_{FB} = 0V$	-	32	-	mΩ
Efficiency	EFFI	$V_{CC} = 12V$, $V_{OUT} = 5V$, $I_{OUT} = 2A$	-	91	-	%
		$V_{CC} = 30V$, $V_{OUT} = 5V$, $I_{OUT} = 2A$	-	86	-	

Application Circuit 1

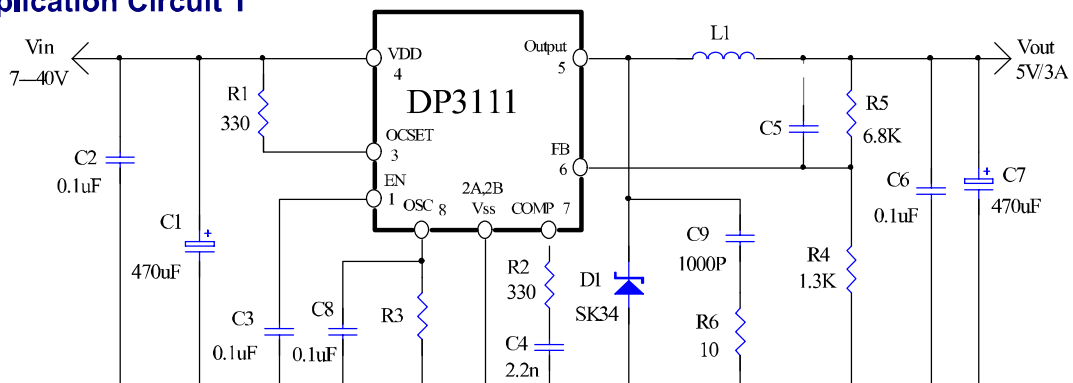



Function Descriptions

EN

This pin can be supplied shutdown function. It is inside pull high function. For normal application, the pin must be connected a capacitor to ground. Allow the switching regulator circuit to be shutdown pulling this pin below a 0.8V threshold voltage; the shutdown supply current is approximately 150uA.

OSC

External frequency set pin. The pin connects a resistance (R3) to reduce system frequency. This converter's frequency can be set from 50K to 600KHz, Please refer the below table to set frequency.

R3	510K	220K	100K	56K	36K	27K	20K
Frequenc	47KHz	100KHz	200KHz	300KHz	400KHz	500KHz	600KHz

COMP

Compensation pin. For EL output capacitor application, the COMP pin connects R2 and C4 to ground for all condition;

OCSET

The current limit threshold is setting by the external resistor connecting from V_{CC} supply to OCSET. The internal 60uA sink current crossing the resistor sets the voltage at pin of OCSET. When the V_s voltage is less than the voltage at OCSET, an over-current condition is triggered.

Application Information

Setting the Output Voltage

Application circuit item shows the basic application circuit with adjustable output version. The external resistor sets the output voltage according to the following equation:

Table 1 Resistor select for output voltage setting

V_{out}	R4	R5
5V	1.3K	6.8K
3.3V	1.5K	4.7K
2.5V	2.2K	4.7K
1.8V	2K	2.5K
1.5V	2.2K	2.0K
1.2V	2K	1K



Inductor Selection

For most designs, the different frequency can be reducing the inductor value; The DP3111 is suggested 15μH to 160μH for 50K to 600KHz frequencies. Please refer the below table to design.

L1 recommend value ($V_{IN}=8\sim 40V$, $V_{OUT}=5V$, $I_{OUT}=3A$)				
Frequency (Hz)	300KHz~600KHz	200K~300KHz	100K~200K	50K~100K
L1 Value (uH)	10uH ~ 22uH	22uH ~47uH	33uH ~68uH	68uH ~160uH

Where is inductor Ripple Current. Large value inductors lower ripple current and small value inductors result in high ripple currents. Choose inductor ripple current approximately 20% of the maximum load current 3A, $\Delta I_L=0.6A$. The DC current rating of the inductor should be at least equal to the maximum load current plus half the ripple current to prevent core saturation ($3A+0.3A$).

Input Capacitor Selection

This capacitor should be located close to the IC using short leads and the voltage rating should be approximately 1.5 times the maximum input voltage. The RMS current rating requirement for the input capacitor of a buck regulator is approximately 1/2 the DC load current. A low ESR input capacitor sized for maximum RMS current must be used. A 470μF low ESR capacitor for most applications is sufficient.

Output Capacitor Selection

The output capacitor is required to filter the output and provide regulator loop stability. The important capacitor parameters are; the 100 KHz Equivalent Series Resistance (ESR), the RMS ripples current rating, voltage rating, and capacitance value. For the output capacitor, the ESR value is the most important parameter. The ESR can be calculated from the following formula.

$$V_{RIPPLE} = \Delta I_L \times ESR = 0.6A \times 80m\Omega = 48mV$$

An aluminum electrolytic capacitor's ESR value is related to the capacitance and its voltage rating. In most case, higher voltage electrolytic capacitors have lower ESR values. Most of the time, capacitors with much higher voltage ratings may be needed to provide the low ESR values required for low output ripple voltage. It is recommended to replace this low ESR capacitor by using a 470μF low ESR values < 80mΩ.



DP3111

PWM Control 3A Step-Down Converter

Demoboard PCB layout

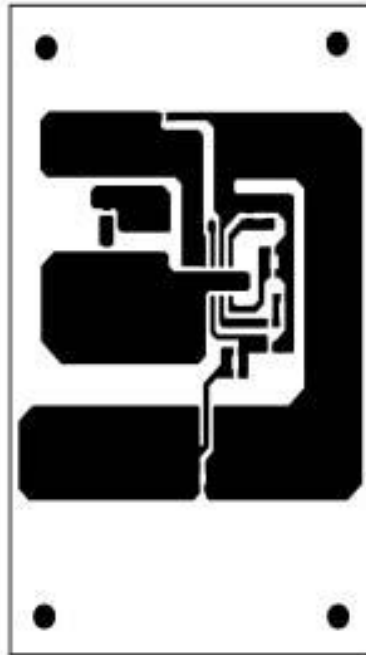
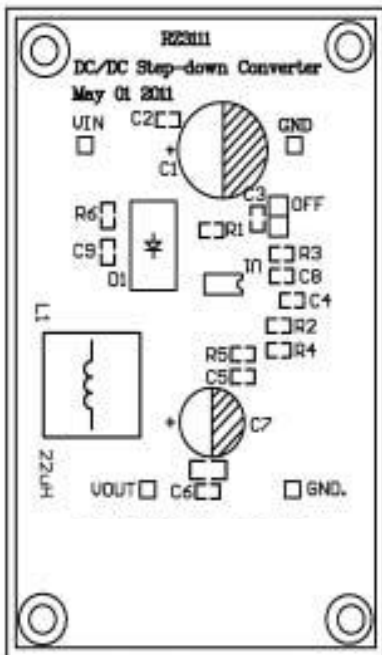



DP3111

PWM Control 3A Step-Down Converter

Package Outlines

